

6LE007709A

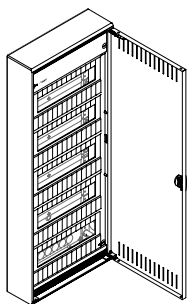

volta AP Stromkreisverteiler

- (GB) Mounting instructions
- (FR) Notice d'instructions
- (DE) Montageanleitung
- (NL) Montage instructie
- (NL) Monteringsvejledning
- (DK) Asennusohje
- (FI) Montasjeanvisning
- (NO) Monterings instruksjoner
- (SE) Istruzioni di montaggio
- (IT) Istrucciones de montaje
- (ES) Instruções de montagem
- (PT) Montážní návod
- (CZ) Uputstvo za montažu
- (BA) Инструкції з установки
- (HR) Upute za montažu
- (HU) Szerelési útmutató
- (LT) Montavimo instrukcija
- (LV) Montāžas instrukcija
- (PL) Instrukcja montażowa
- (RO) Instrucțiuni de montare
- (RO) Návod na montáž
- (SK) Указания по установке
- (RU) Инструкции за монтаж
- (BG) ---
- (GR) Navodilo za montažo
- (SI) Paigaldusjuhised
- (EE) Leiðbeiningar
- (IS) ---
- (AR) ---

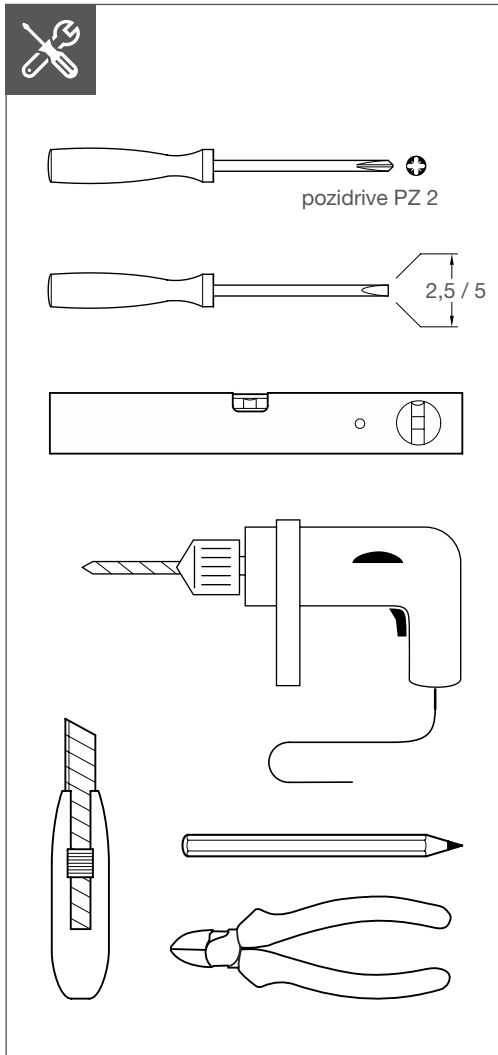
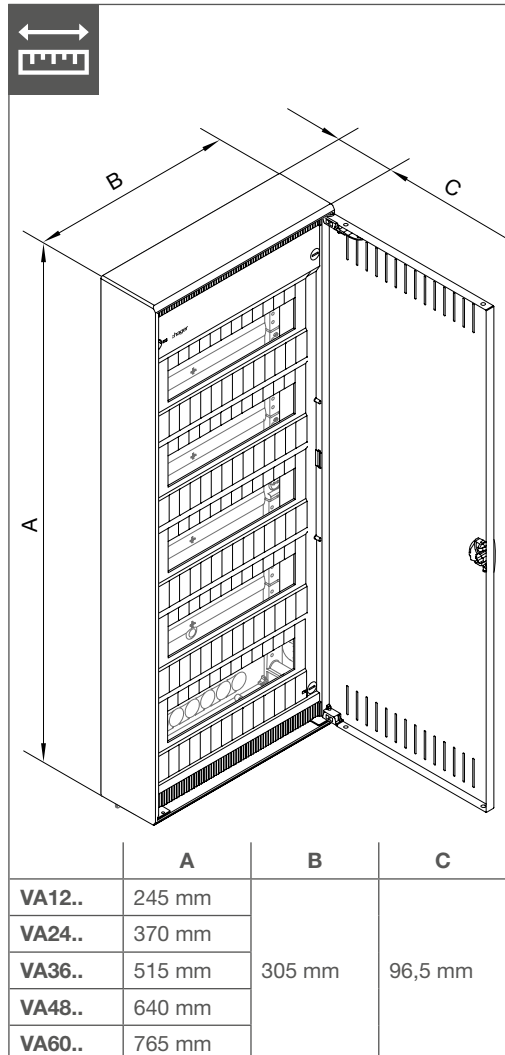
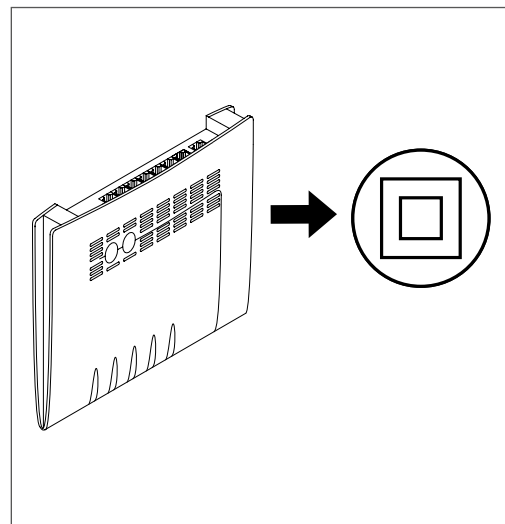
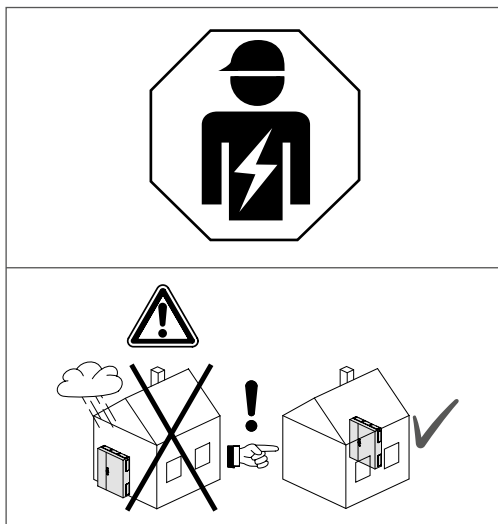
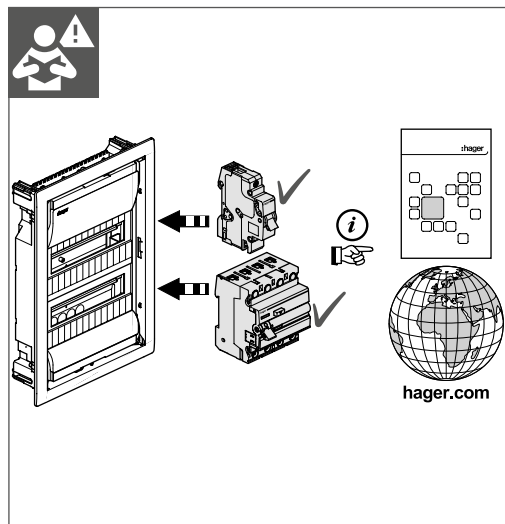

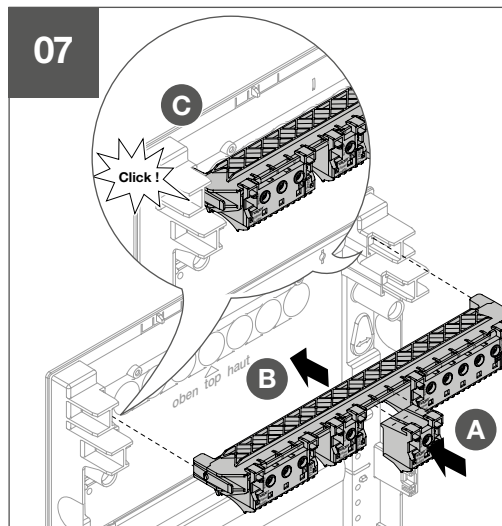
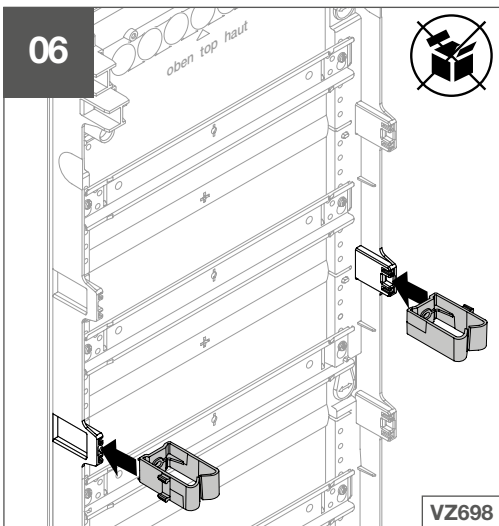
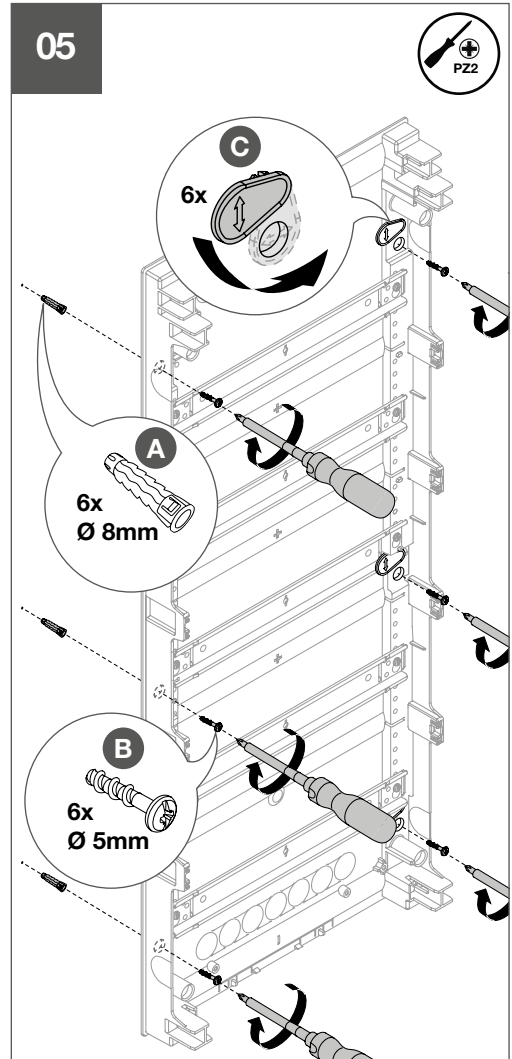
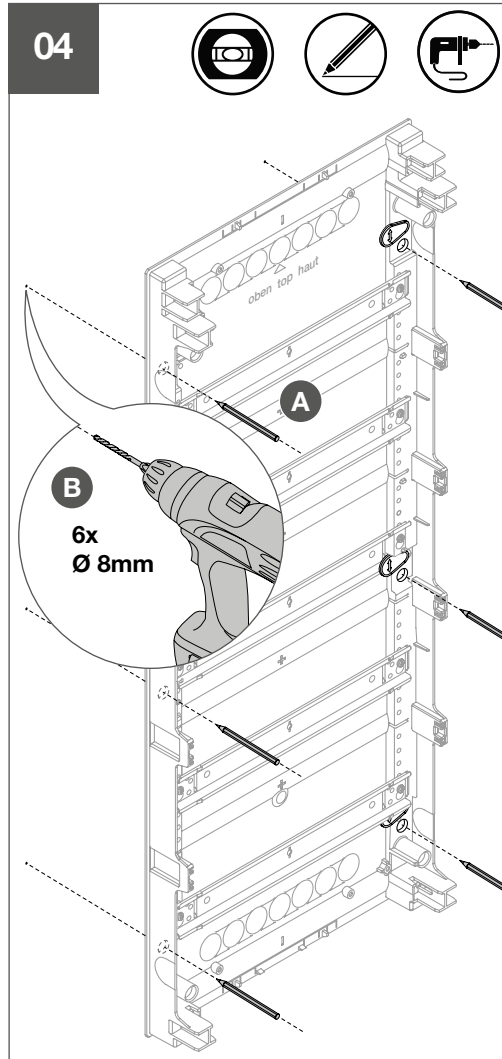
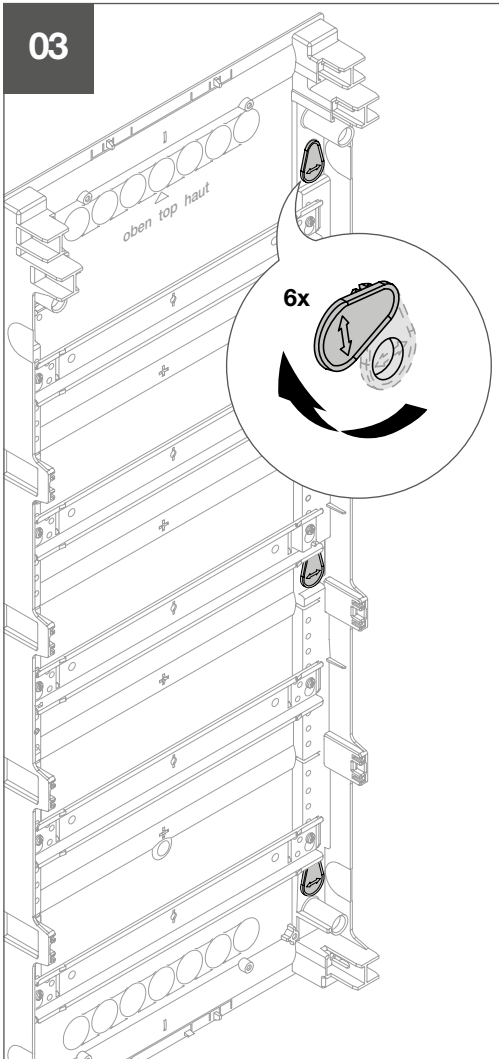
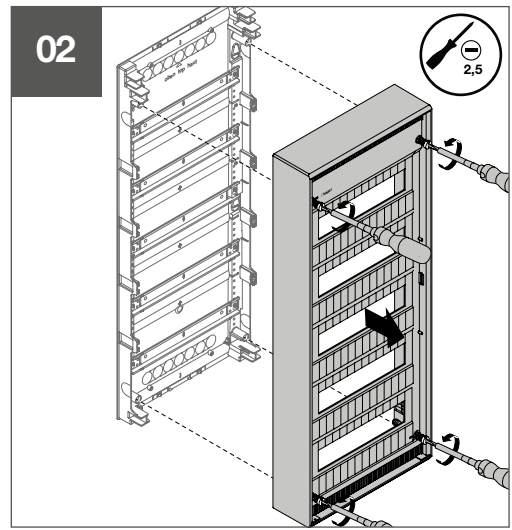
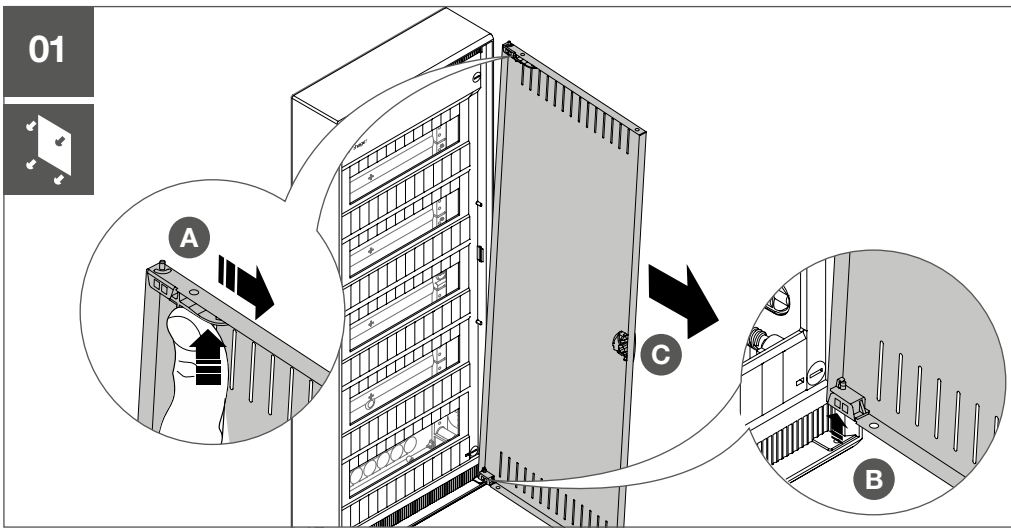

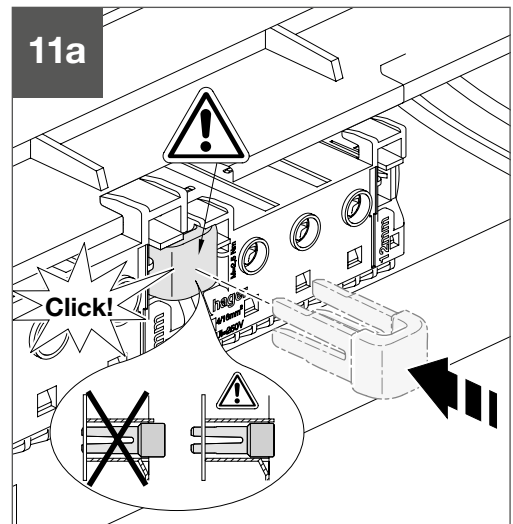
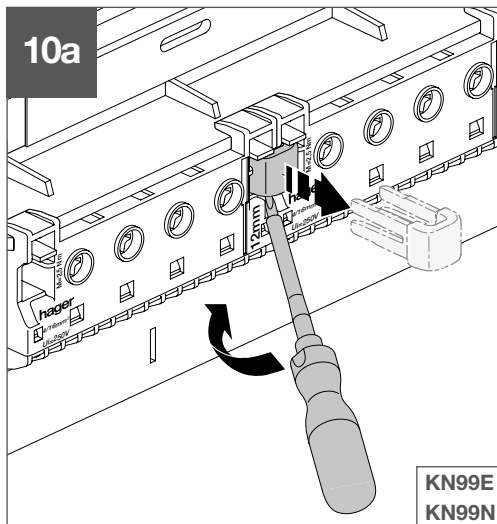
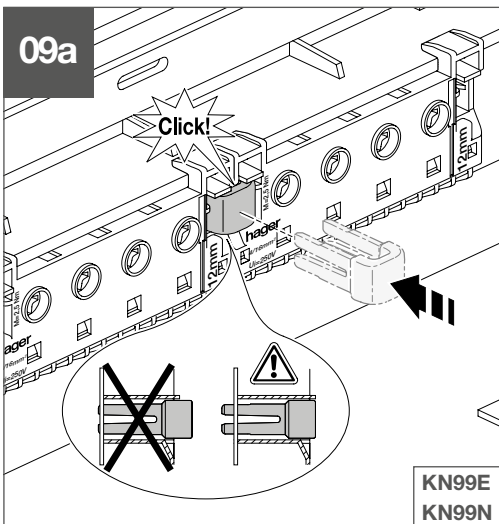
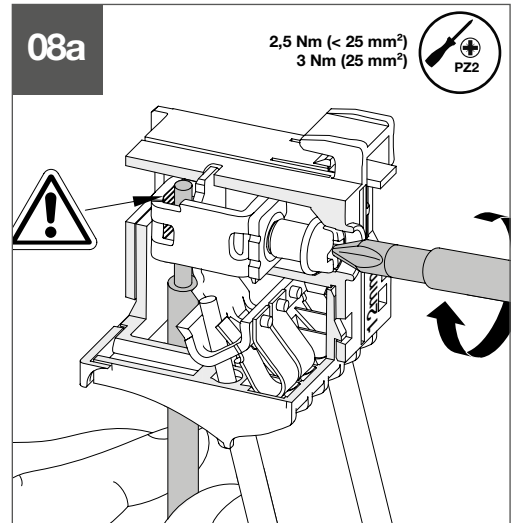
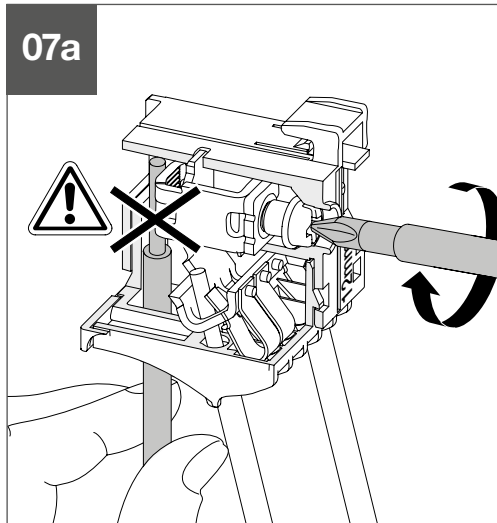
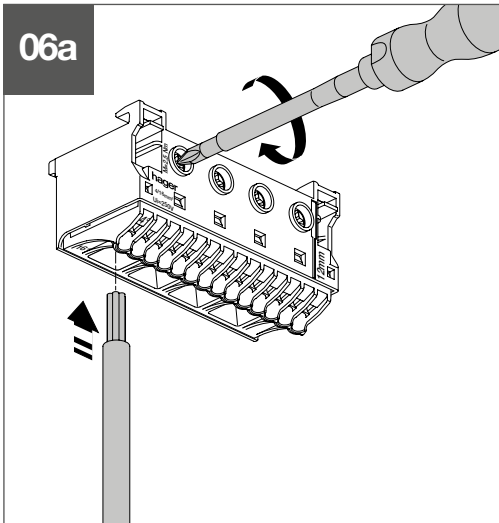
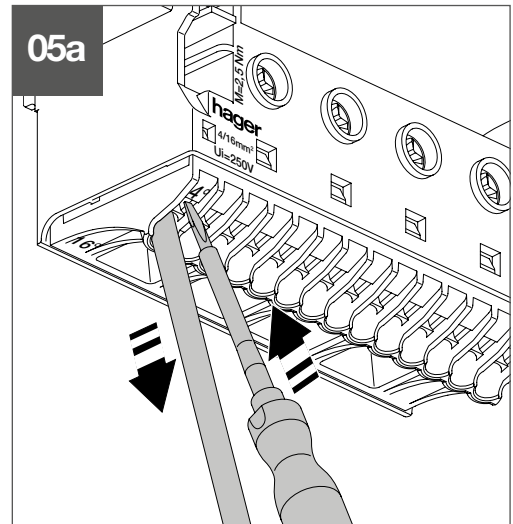
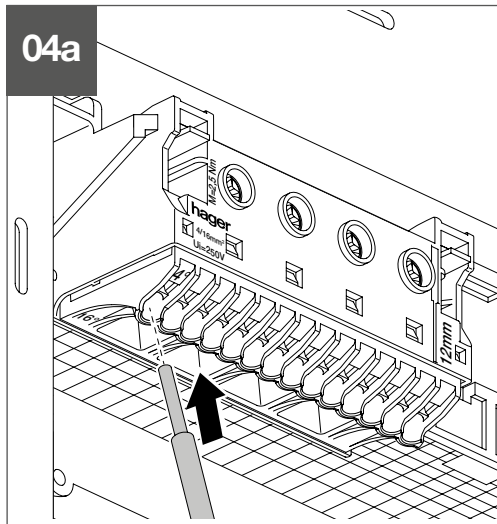
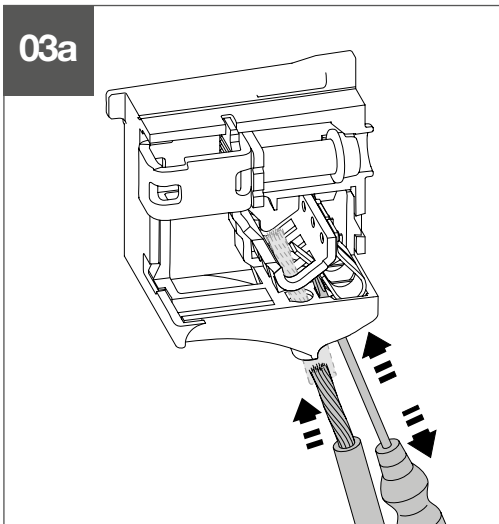
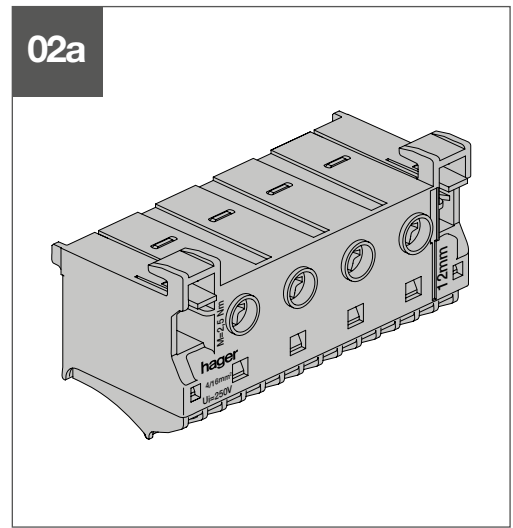
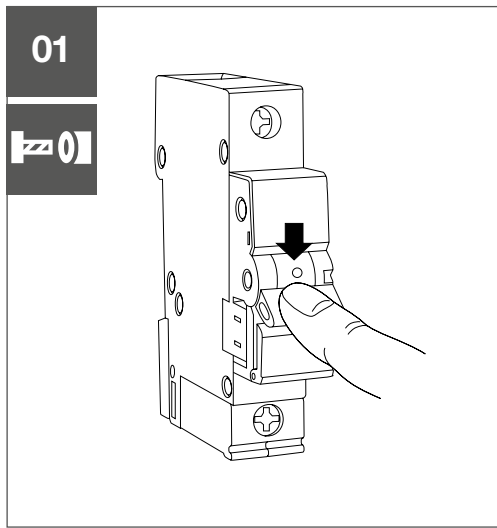
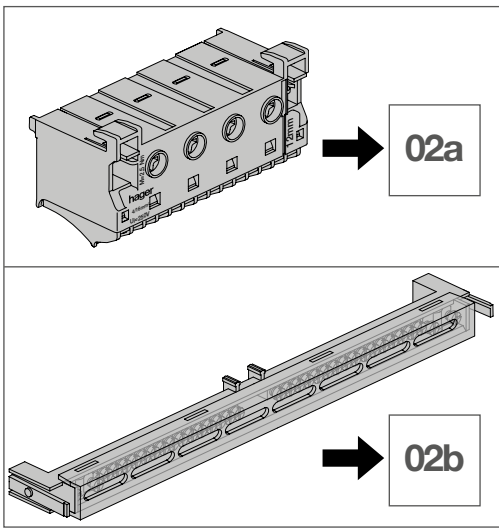

02b

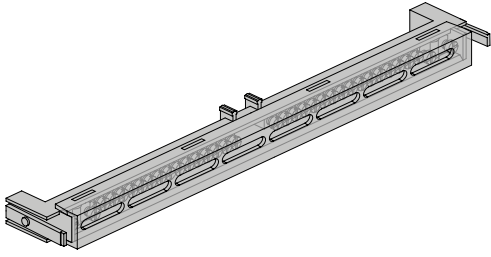

03b

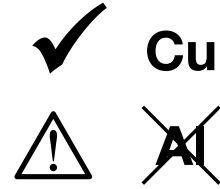
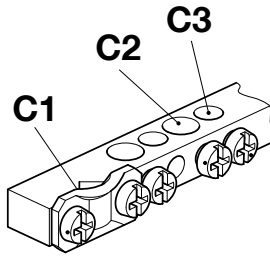

				Class 1*	Class 2*	Class 5*
C1	2x M4	1,7 Nm	9 mm	10-16 mm ²	10-25 mm ²	
C2	M5	2,3 Nm		1,5-16 mm ²		
C3	M4	1,7 Nm		1,5-10 mm ²		

* IEC 60228

01

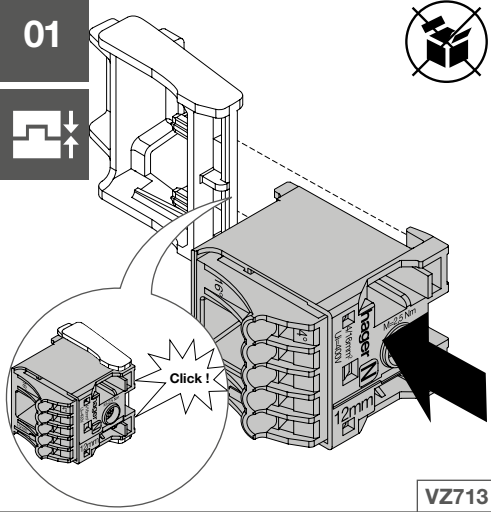

VZ713

02

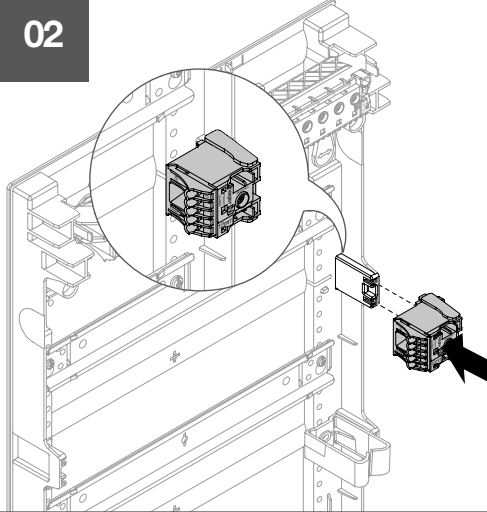

03

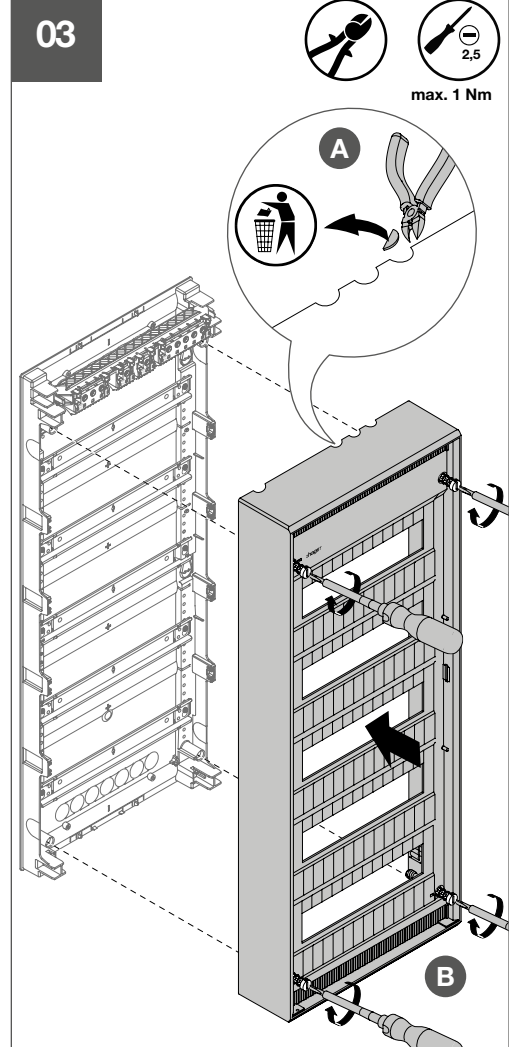

04

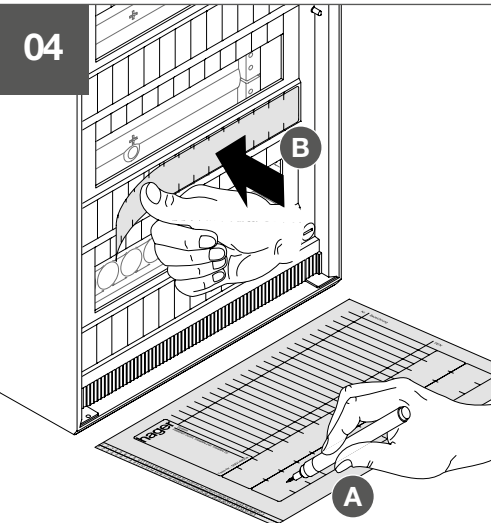

05

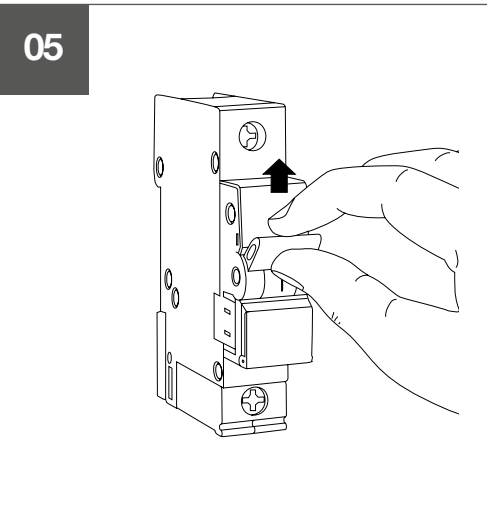

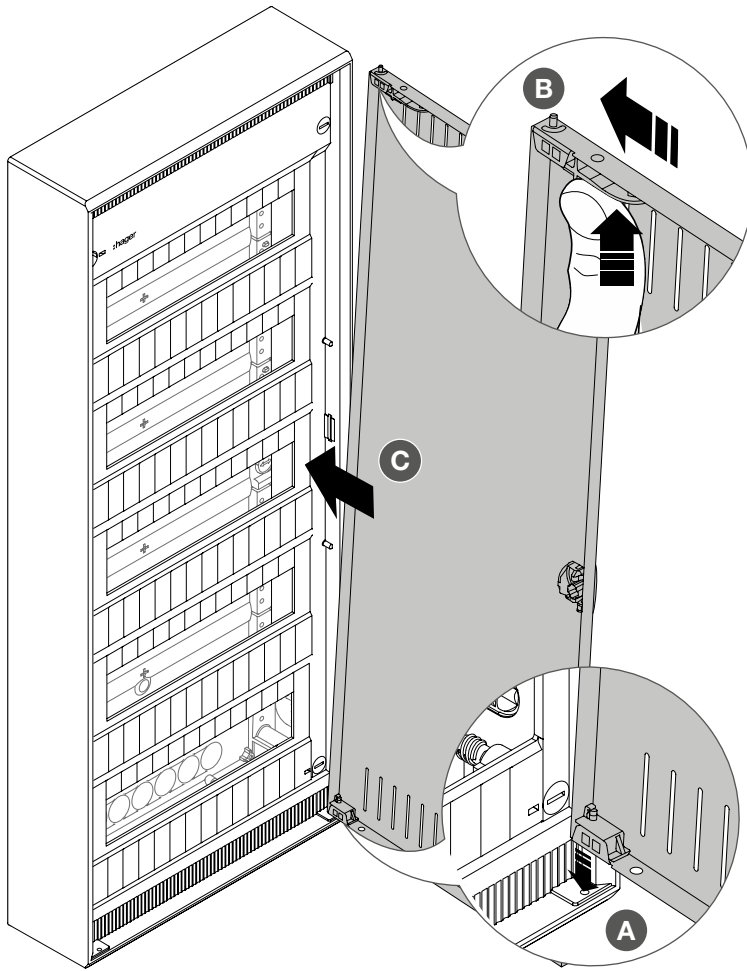

company, entreprise, Firma	01 01 2020
address, adresse, Adresse	f _n ## Hz
address, ad	U _n ## V
N°: order, ordre, Auftrags-	I _{nA} ## A
permanent marker	
IEC/EN 61439-3	

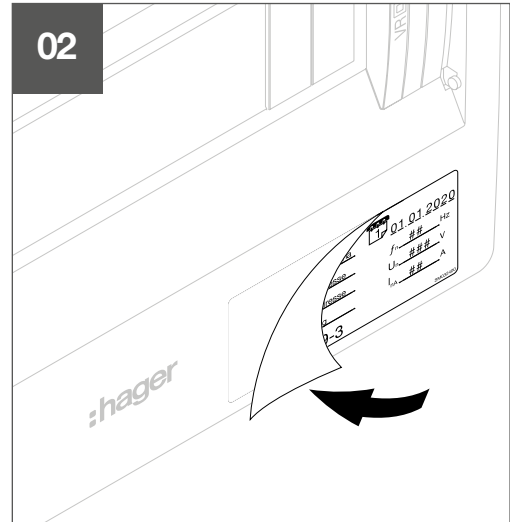
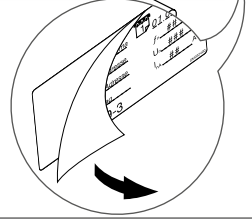

- (EN)** The Assembly (DBO) designated markings must be completed as specified in IEC/EN 61539 - 3 clause 6.1.
- (FR)** Le marquage de l'installation à basse-tension (DBO) doit être renseigné avec les spécifications techniques indiquées dans la norme IEC/EN 61439-3 paragraphe 6.1.
- (DE)** Die Schaltgerätekombination (DBO) muss mit den Aufschriften nach IEC/EN 61439-3 Abschnitt 6.1 gekennzeichnet werden.
- (NL)** De voor Assemblage (DBO) bestemde markeringen moeten worden ingevuld zoals gespecificeerd in IEC/EN 61439-3 paragraaf 6.1.
- (DA)** DBO-mærkningerne (markeringsmærkerne) skal udfyldes som specificeret i IEC/EN 61439-3 punkt 6.1.
- (FI)** Maallikkokäyttöön tarkoitettujen jakokeskuksen merkinnät on täytettävä IEC/EN 61439-3:n lusekkeen 6.1 mukaisesti.
- (NO)** Enhetens (fordelingskort) merking må være komplett som spesifisert i IEC/EN 61439-3 klausul 6.1.
- (SV)** Kopplingsutrustningen måste märkas med etikett i enlighet med IEC / EN 61439-3 avsnitt 6.1.
- (IT)** Le marcature designate per l'assemblaggio (DBO) devono essere integrate come specificato nella norma IEC/EN 61439-3 sezione 6.1.
- (ES)** El conjunto de la aparamenta debe estar señalizado/ marcado de acuerdo con la norma IEC 61439-3 sección 6.1.
- (PT)** As marcações designadas devem ser realizadas conforme especificado na IEC/EN 61439-3 cláusula 6.1 para o Conjunto (DBO).
- (CS)** Označení určená pro montáž (DBO) musí být vyplněny podle specifikace normy IEC/EN 61439-3, článku 6.1.
- (HR)** Oznake za sklapanje (DBO) moraju biti navedene prema preporukama iz IEC/EN 61439-3, klauzule 6.1.
- (HU)** A berendezés (DBO) felirati megjelölésének összhangban kell lennie az IEC/EN 61439-3 szabvány 6.1 pontjában foglaltakkal.
- (LT)** Montážas (DBO) apžīmėjumiem jāatbilst IEC/NE 61439-3 6.1. punkta prasībām.
- (LV)** Montāžas (DBO) marķējums jāiekļauj Standarta IEC/EN 61439-3 6.1. punktā norādītā informācijā.
- (PL)** Rozdzielnica musi być oznakowana zgodnie z IEC/EN 61439-3 rozdział 6.1.
- (RO)** Marcajele destinate ansamblurilor (DBO) trebuie completate conform precizărilor din standardul IEC/EN 61439-3 punctul 6.1.



- (RU)** Должна быть выполнена маркировка для сборки (Распределительные щиты, обслуживаемые лицами без специальной квалификации (DBO)) в соответствии с требованиями стандарта IEC/EN 61439-3, пункт 6.1.
- (BS)** Obznaceniya za montazh (DBO) treba da odgovaraju na iziskivanja, posoceni u IEC/EN 61439-3, točka 6.1.
- (EL)** Οι σημάνσεις συναρμολόγησης (DBO) πρέπει να συμμορφώνονται με τη ρήτρα 6.1 του προτύπου IEC/EN 61439-3.
- (SK)** Označe, določene za sestav (DBO), morajo biti izpolnjene v skladu s klavzulo 6.1 standarda IEC/EN 61439-3.
- (SK)** Označenia určené pre montáž (DBO) musia byť vyplnené podľa špecifikácie normy IEC/EN 61439-3, článku 6.1.
- (EE)** Koosteale (DBO) lisatud märgised peavad vastama standardi IEC/EN 61439-3 punktile 6.1.
- (IS)** Merkingar samsetningar (DBO) verða að vera útfylltar eins og tilgreint er í ákvæði 6.1 í IEC/EN 61439-3.